



# THE EXTRUDER/FEEDER

## A CONTINUOUS HYDRO-FEED AUGER SYSTEM FOR INCINERATION

*innovative waste processing systems*

### MATERIALS PROCESSED:

- Animal Carcasses
- Coarse Waste
- Resins
- Tars
- Filter Cake
- Soils
- Rocks
- Asphalt
- Overpacks
- Drums
- Supersacs
- Polymers
- Paint Sludge
- Tyvek Suits
- Clay
- Wood Waste
- Plastic Pieces
- Concrete
- Organic Waste

\* Some material can only be processed in larger units.

### UTILIZATION BY:

- Energy Recovery Systems (Industrial, Utilities, etc.)
- Incineration Operations
- Heavy Industrial Applications
- Hazardous and Low Level Radioactive Facilities
- Governmental Contracts (weapon destruction, low grade radioactive contaminated material reduction)
- OEM (manufacturers of rotary kilns and fluidized bed)
- Medical Waste Sterilization Systems

### BENEFITS:

- Shred/ Feed single step (larger models only)
- Variable feed rate (less than 1 rpm possible)
- Compression Auger create material plug to reduce burn back and leakage
- Batch infeed/continuous output
- Increased incineration efficiency - increased throughput
- Unique design tolerant of tramp material
- Low-speed, high-torque, low-horsepower design
- Compact design - reduced footprint requirement

Optional accessories -- see reverse side

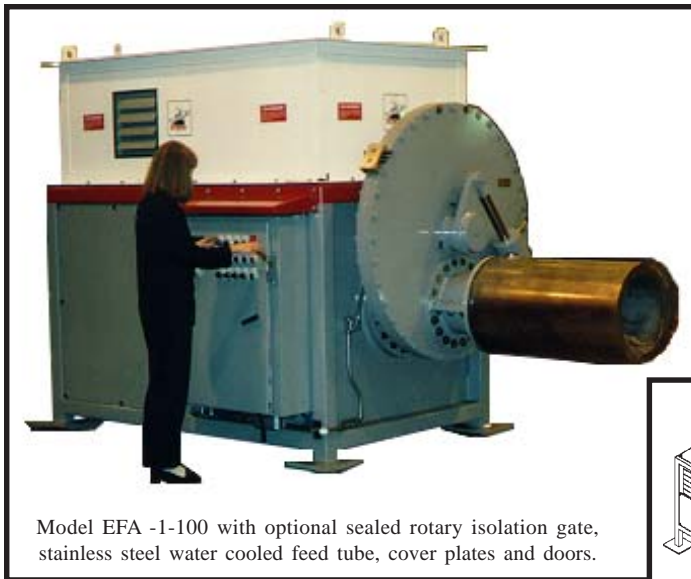

Model EFA -1-100 with optional sealed rotary isolation gate, stainless steel water cooled feed tube, cover plates and doors.



Model EFG-1-150 ideally suited for this sludge pond clean-up

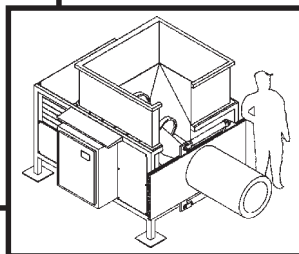

Model FB-1-20 with isolation gate



Model EFG-1-150 with optional guillotine isolation gate and special feed hoppers.



Dupont's model HFG-1-100 processing plastics



Easy to Maintain Screw Auger

The KOMAR extruder/feeder provides a wide spectrum of feeding capability with variable feed rate (PLC controlled) and continuous output. The compression auger offers the ability to produce a plug to prevent burn back potential and reduce air leakage. The unique design handles waste with varying physical and chemical characteristics including: solids and sludges with high and low Btu and literally thousands of different compounds. A blend of material is ideally suited for this type of feeder.

## KOMAR INDUSTRIES, INC.

4425 Marketing Place  
Groveport, Ohio 43125

TEL: (614) 836-2366

FAX: (614) 836-9870

U. S. and Foreign Patents Issued and Pending



Visit Komar on the World Wide Web: [komarindustries.com](http://komarindustries.com)

Or E-mail us at: [info@komarindustries.com](mailto:info@komarindustries.com)

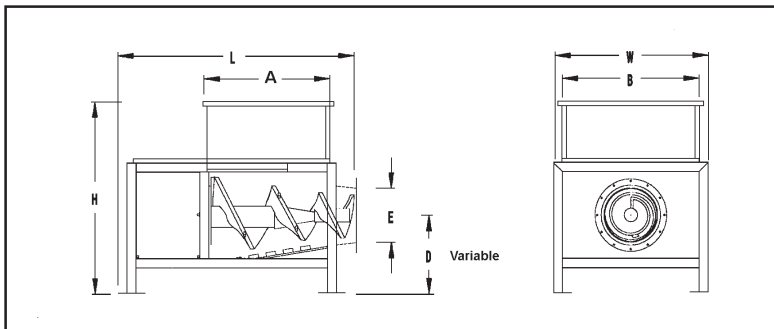

### Optional Accessories

- Service Platform
- Fire Suppression System
- Custom Designed Support Stand
- Elevator
- Video Monitoring
- Electronic Oxygen Monitoring
- Nitrogen Purging
- Water Cooled Extrusion Tube
- Isolation Gates
- Airlock Chambers
- Skip Hoist
- Conveyors
- Enclosure Cover & Doors

TECHNICAL DATA: VARIABLE SPEED LIGHT DUTY DRY MATERIALS				
MODEL	IFA-10000	FD-1-40	FG-1-75	FP-1-150
Electric drive (hp)	10	40	75	150
Voltage	380 v, 3 ph, 50 Hz	480 v, 3 ph, 60 Hz	480 v, 3 ph, 60 Hz	480 v, 3 ph, 60 Hz
Infeed Charge Opening (AB)	24" x 24"	52" x 60"	62" x 70"	72" x 100"
RPM Auger (variable)	3 to 10	3 to 14	3 to 15	3 to 15
Shaft	6" tapered to 3"	8" tapered to 6"	8" tapered to 6"	12" tapered to 6"
Screw Flighting (thick: tapered)	1/2" : 14" - 8"	1 1/2" : 34" - 18"	1 1/2" : 40" - 20"	1 1/2" : 52" - 24"
Auger Thrust	80,000	157,000	169,000	210,000
Hydraulic Power Unit	Stand Alone	integrated within unit	integrated within unit	integrated within unit
Dimensions of Shredder (LWH)	54" x 42" x 60"	110" x 76" x 96"	127" x 80" x 96"	155" x 100" x 110"
Weight of Shredder approx.	4,000	22,000	33,500	42,000

TECHNICAL DATA: VARIABLE SPEED HEAVY DRY MATERIALS				
MODEL	HFB-1-40	HFD-1-75	HFG-1-100	HFP-1-200
Electric drive (hp)	40	75	100	200
Voltage	480 v, 3 ph, 60 Hz	480 v, 3 ph, 60 Hz	480 v, 3 ph, 60 Hz	480 v, 3 ph, 60 Hz
Infeed Charge Opening (AB)	39" x 36"	52" x 60"	62" x 70"	72" x 100"
RPM Auger (variable)	1 to 15	1 to 18	1 to 18	1 to 20
Shaft	8" tapered to 4"	12" tapered to 6"	16" tapered to 6"	16" tapered to 6"
Screw Flighting (thick: tapered)	2 1/2" : 20" - 10"	2 1/2" : 34" - 18"	2 1/2" : 40" - 20"	2 1/2" : 52" - 24"
Auger Thrust	170,000	180,000	215,000	385,000
Remote HPU	Stand alone	Stand alone	Stand alone	Stand alone
Dimensions of Shredder (LWH)	106" x 60" x 65"	119" x 86" x 96"	136" x 90" x 106"	165" x 132" x 123"
Weight of Shredder approx.	18,000	26,000	35,000	47,000

TECHNICAL DATA: VARIABLE SPEED HEAVY SOLIDS, SLUDGE, LIQUIDS WITH SOLIDS MATERIALS				
MODEL	EFB-1-75	EFD-1-100	EFG-1-150	EFP-1-300
Electric drive (hp)	75	100	150	300
Voltage	480 v, 3 ph, 60 Hz	480 v, 3 ph, 60 Hz	480 v, 3 ph, 60 Hz	480 v, 3 ph, 60 Hz
Infeed Charge Opening (AB)	39" x 36"	52" x 60"	62" x 70"	72" x 100"
RPM Auger (variable)	1 to 20	1 to 22	1 to 21	1 to 23
Shaft Solid Steel	8" tapered to 4"	12" tapered to 6"	16" tapered to 6"	16" tapered to 6"
Screw Flighting (thick: tapered)	2 1/2" : 20" - 10"	2 1/2" : 34" - 18"	2 1/2" : 40" - 20"	2 1/2" : 52" - 24"
Auger Thrust ft./lbs.	200,000	240,000	305,000	427,000
Remote HPU	Stand alone	Stand alone	Stand alone	Stand alone
Dimensions of Shredder (LWH)	100" x 60" x 65"	113" x 86" x 96"	133" x 90" x 106"	162" x 132" x 123"
Weight of Shredder approx.	22,000	33,000	43,000	52,000

Specifications are subject to change.

\* "B" series should only be used with pre-sized material.



Nan Ya Plastics Corp. in Taipei, Taiwan has a KOMAR auger processor for processing cardboard boxes, pallets and other typical industrial trash for direct feed into their incinerator.

Model HFB-1-40 with guillotine isolation gate and water cooled tube.



Wood waste

Model HFD-1-75 with water cooled tube and guillotine isolation gate



Medical waste

Model FP-1-150 processing industrial dunnage



Komar Industries, Inc. custom engineers, manufactures, installs, and services complete waste processing systems for virtually all types of solid, semi-solid, hazardous, and non-hazardous materials and waste streams.

Call or write: **KOMAR INDUSTRIES, INC.**  
4425 Marketing Place  
Groveport, OH 43125

Tel: 614 - 836 - 2366  
Fax: 614 - 836 - 9870  
International Calling Code for  
United States is 1

Video Demonstrations  
Available



WASTEC