



Komar Auger-Pak®

Quality Made
in the USA



Since 1977

Heavy-Duty Industrial Cardboard Compactor

EM-40GHS



EM-40GHS with dock enclosure

- Located outside your facility
- Shreds and compacts in one machine
- Significant volume reduction increases payload weights & lowers transportation costs
- Maximum uptime with minimal maintenance
- No more double/triple material handling
- Connects to standard receiving container
- Clean quiet electric drive, no hydraulic leaks

Komar EM-40GHS Auger-Pak®

The EM-40GHS Auger-Pak® is designed for high-volume Fulfillment Centers to provide reliable continuous box evacuation from both conveyor, and cart dumper systems. The Komar Auger-Pak® maximizes cardboard processing, shredding and compacting directly into a standard 40 cubic yard receiving container. The powerful all-electric drive, in combination with our proprietary auger screw shaft and solid cast steel flights, assures high density loads for recycling. The material is reduced in volume up to 6 times providing consistent 6 to 10 ton loads*. Komar uses only the highest quality, precision made parts to ensure significantly increased machine life with very low maintenance. Located outside your facility, the Komar Auger-Pak™ frees up valuable floor space for your main business operations.



* Systems that are hand or conveyor fed typically achieve higher compaction levels. When materials are fed with a tipper or self-dumping hopper, meter feeding is important to achieve similar levels of compaction.

Groveport, OH

(614) 836-2366

www.komarindustries.com

info@komarindustries.com

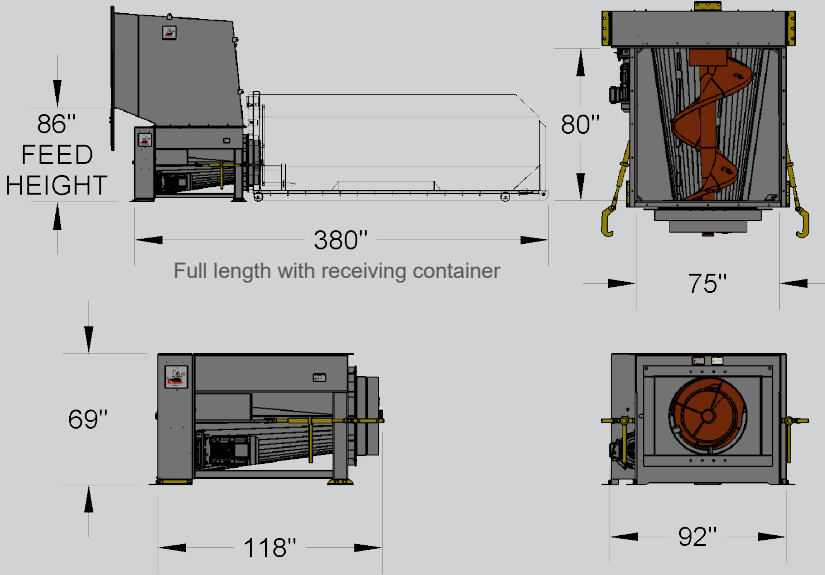

Dimensions and process data for reference only

Processing Specifications	
Horsepower	40
Tons per Hour	5
Feed Type	Hand, Forklift, Tipper, Conveyor, Chute
Receiving Container	Roll-Off 50 cu. yd.
Tons Per Container	6-10

Machine Specifications	
Footprint (L x W x H)	118" x 92" x 69"
Chamber Size (L x W)	80" x 75"
Full System Weight (lbs.)	18,825
Rpm / Torque (ft.-lbs.)	14.83 / 14,165.39

INSTALLATION TYPES

Dock Enclosure with Tipper

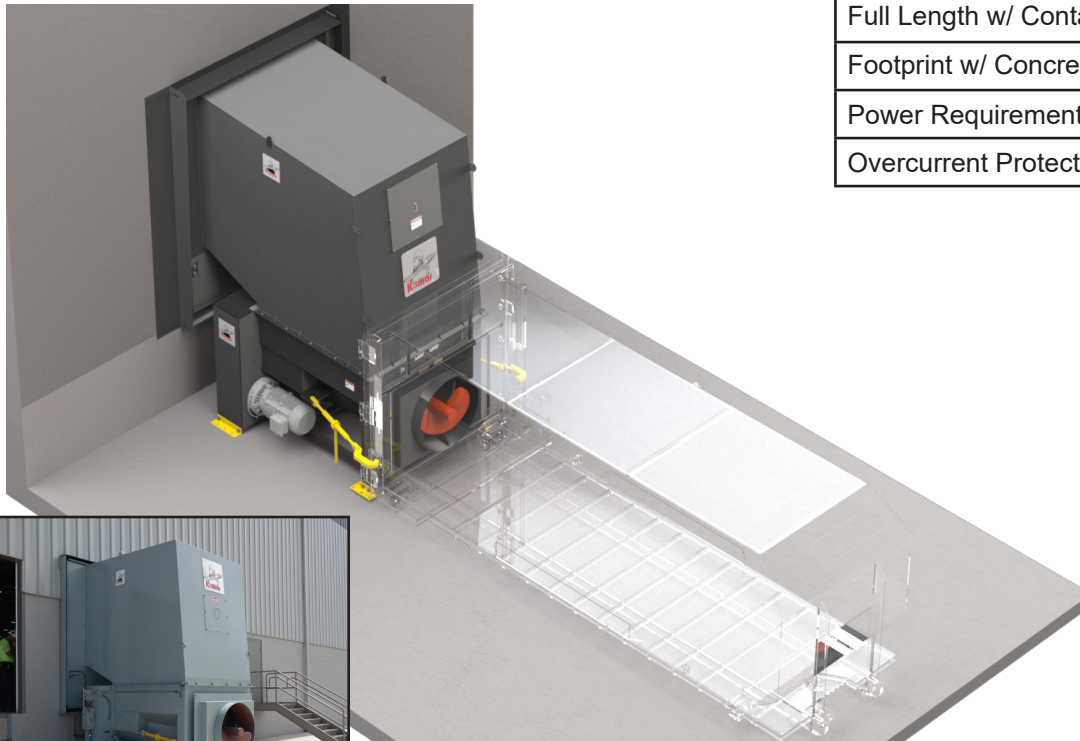

- Shown at 9' x 10' standard dock door.
- Shown with clear standard receiving container to illustrate attachment.

Installation Requirements	
Full Length w/ Container	380"
Footprint w/ Concrete Pad	404" x 117"
Power Requirement	3 phase, 460/480 V, 60 Hz
Overcurrent Protection	125 amp MCP type breaker



Inside View

Dock Enclosure with Tipper and Conveyor Feed



- Shown at 9' x 16' dock door with tipper and conveyor feed.
- Shown with clear standard receiving container to illustrate attachment.



Inside View

Chute Feed

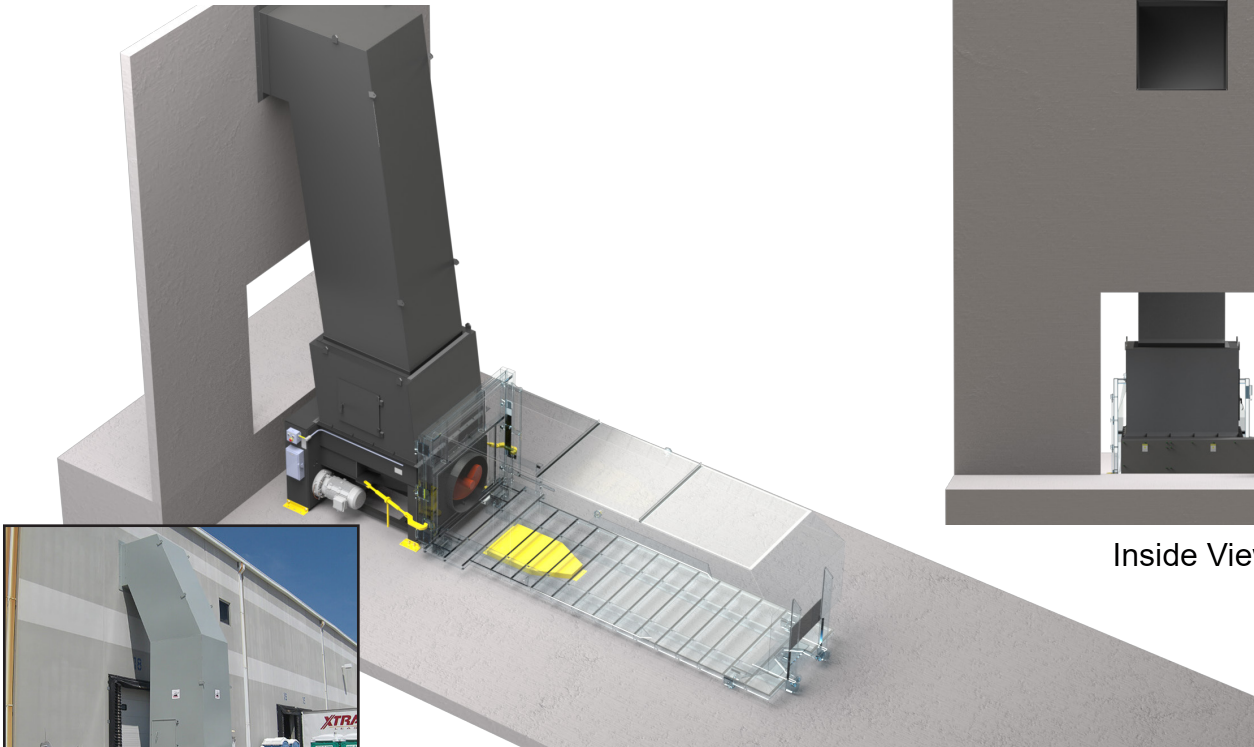

- Shown at 9' x 10' standard dock door.
- Shown with clear standard receiving container to illustrate attachment.



Inside View



Komar Auger-Pak®

EM-GHS Technology Overview

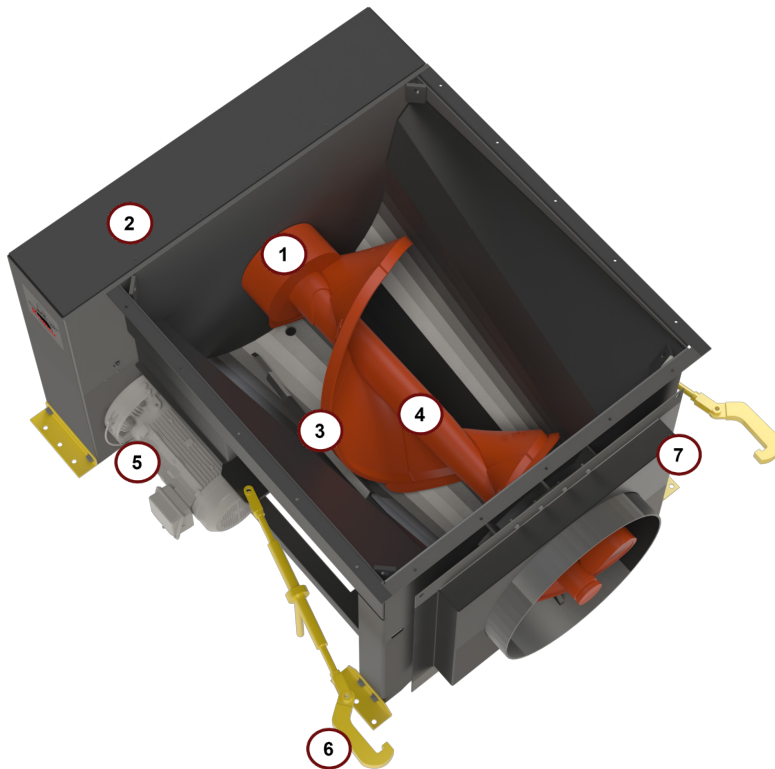

① Patented Solid Lube Bearing Support System

Allows for the use of the biggest and most powerful auger screws in the industry, resulting in maximum compaction force.

② Worry-Free Chain and Bearing Lubrication System

The engineered, automatically lubricated chain, coupled with the self-lubricated bearing system cuts down on routine maintenance.

③ Cast Steel Flights ④ Tapered Solid Alloy Steel Shaft

Using the highest quality components to construct our auger screws extends service life. The mass and shape of the cast flights increases overall strength and durability, while providing more efficient material delivery to the receiving container. Our patented tapered shaft uniquely distributes force along the shaft, minimizing stress on the bearings and maximizing screw life.

⑤ Cycloidal Drive with 500% Shock Load

Don't judge a drive strictly by the motor's horsepower, especially when you plan to process heavy industrial materials. A high shock load rating is important in giving the compactor the ability to crush through large loads without causing damage to the drive.

⑥ Ratchet Binders ⑦ Container Adaptor

The auger compacts directly into a standard roll-off receiving container typically provided by your local hauler, and meets ANSI and OSHA specifications.