



Komar Auger-Pak®

Quality Made
in the USA



Since 1977

Heavy-Duty Industrial Wood Pre-Crushing Compactor

EM-60W



EM-60W with dock enclosure hopper

- Quickly rids yard and facility of wood waste
- Shreds and compacts in one machine
- Significant volume reduction increases payload weights & lowers transportation cost
- Machine processing is safer for employees
- Eliminates manual sawing or handling
- Handles nails, bolts, hinges, and corner bracing
- Connects to standard receiving container
- Clean quiet electric drive, no hydraulic leaks

Komar EM-60W Auger-Pak®

The Komar EM-60W Auger-Pak® is a heavy-duty, all-electric industrial pre-crushing compactor, ideally suited for 84" x 48" pallets, wooden crates up to 60" x 48" x 48", and spools with a 60" diameter. Occasional pieces up to 120" in length can be processed, but may require additional handling. The Auger-Pak® features top of the line processing components. Constructed with a solid steel shaft and cast alloy steel flights, the auger screw effortlessly shreds & compacts material directly into a standard 40 cubic yard receiving container. The powerful all-electric cycloidal drive generates high-density payloads, while eliminating the hydraulic oil leaks inherent in ram style compactors. In addition, the auger's automated processing will cut labor cost while making your workplace safer.



* Load weights vary depending on material and loading method

Groveport, OH

(614) 836-2366

www.komarindustries.com

info@komarindustries.com

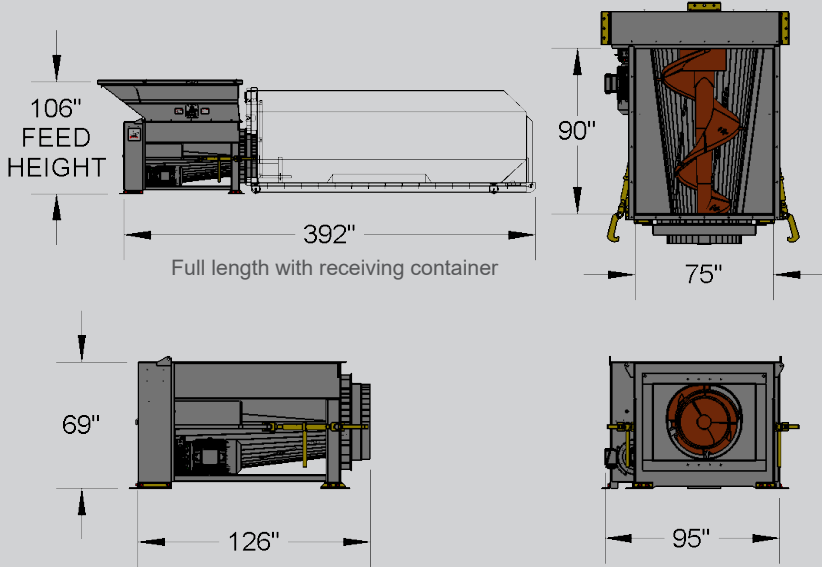

Dimensions and process data for reference only

Machine Specifications	
Horsepower	60
Footprint (L x W x H)	126" x 95" x 69"
Process Chamber (L x W)	90" x 75"
Full System Weight (lbs.)	24,358
RPM / Torque (ft.-lbs.)	10.17 / 30,972

Processing Specifications	
Peak Tons per Hour	8
Standard Pallets/Charge	12
Pallet Size* (L x W)	84" x 60"
Crate Size* (L x W x H)	84" x 48" x 48"
Cable Spool Size* (dia.)	60"

* Occasional pieces up to 96" in length can be processed but will require special handling.

INSTALLATION TYPES

Yard

Installation Specifications	
Full Length w/ Container	392"
Footprint w/ Concrete Pad	415" x 119"
Power Requirement	3 phase, 460/480 V, 60 hz
Overcurrent Protection	175 amp

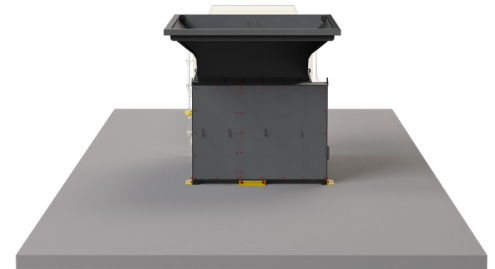
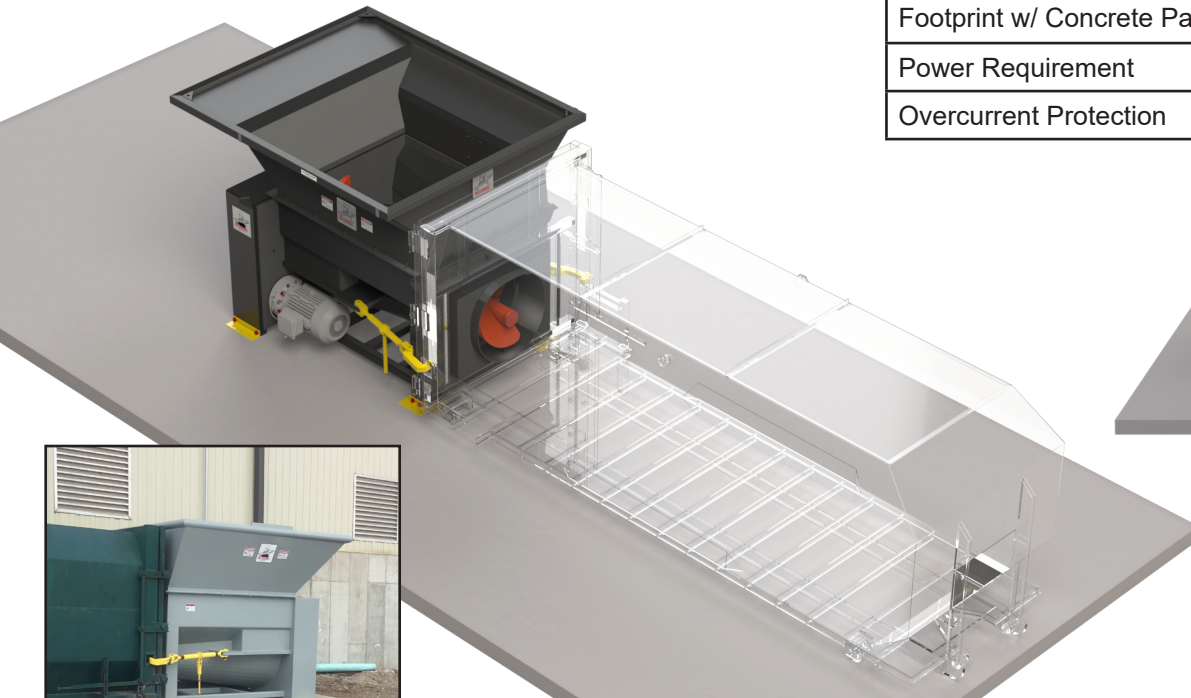

Rear View



• Shown with clear standard receiving container to illustrate attachment.

Open at Dock

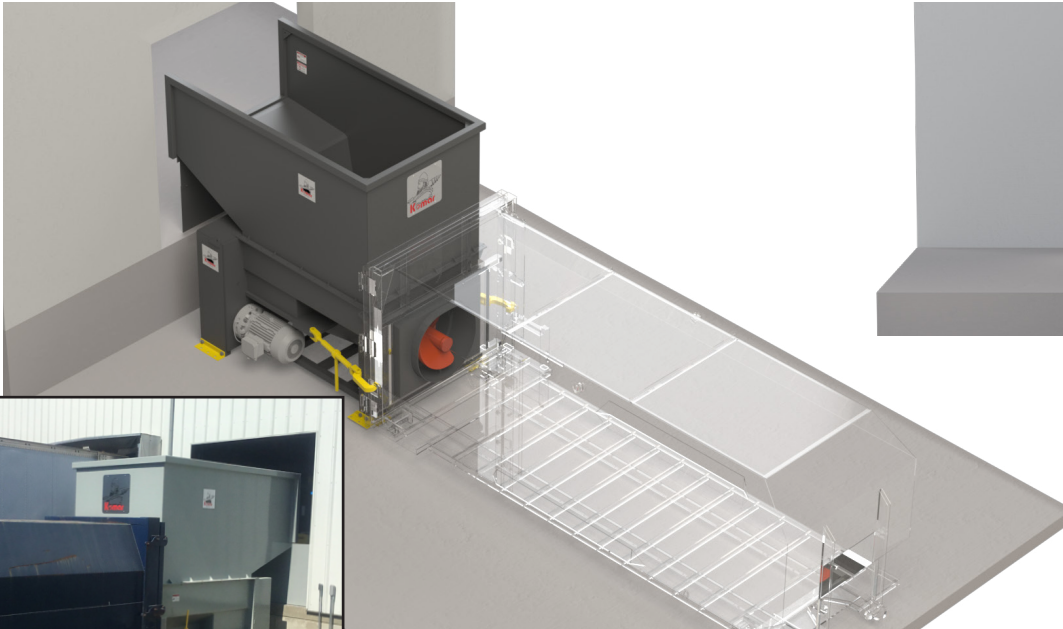

Inside View



- Shown at 9' x 10' Standard Dock Door.
- Shown with clear standard receiving container to illustrate attachment.

Dock Enclosure

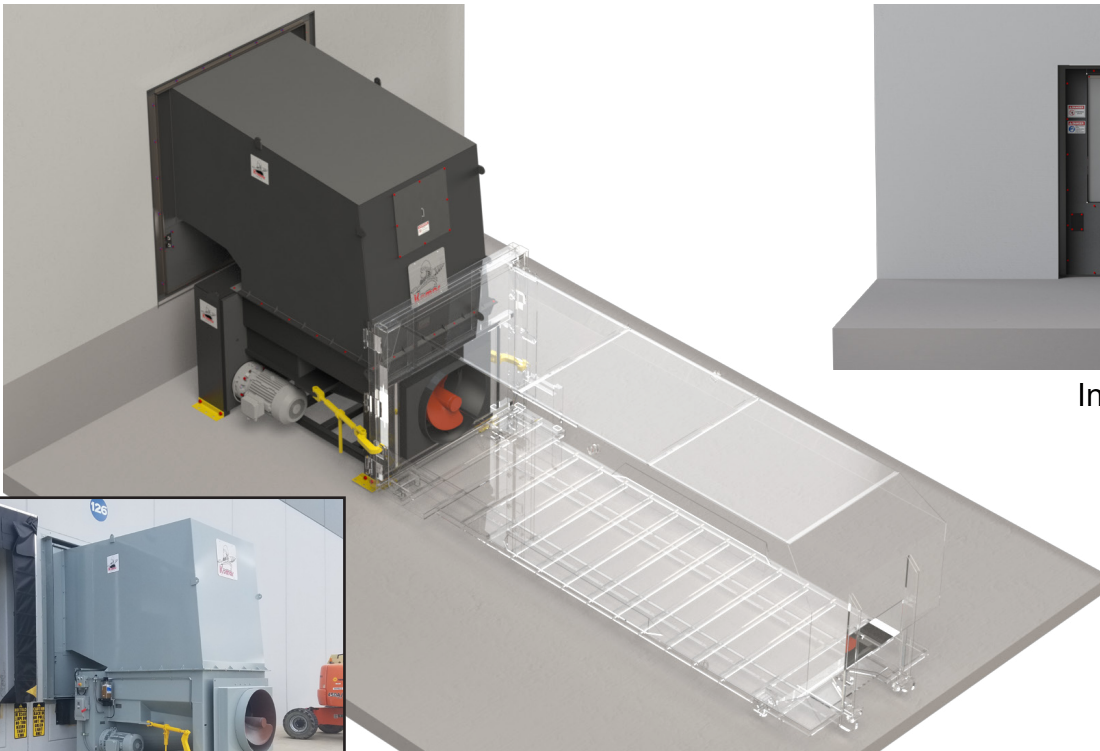

Inside View



- Shown at 9' x 10' Standard Dock Door.
- Shown with clear standard receiving container to illustrate attachment.



Komar Auger-Pak[®]

EM-W Technology Overview

① Patented Solid Lube Bearing Support System

Allows for the use of the biggest and most powerful auger screws in the industry, resulting in maximum compaction force.

② Teeth

All of our wood machines include teeth to help with the initial breakdown of dense material.

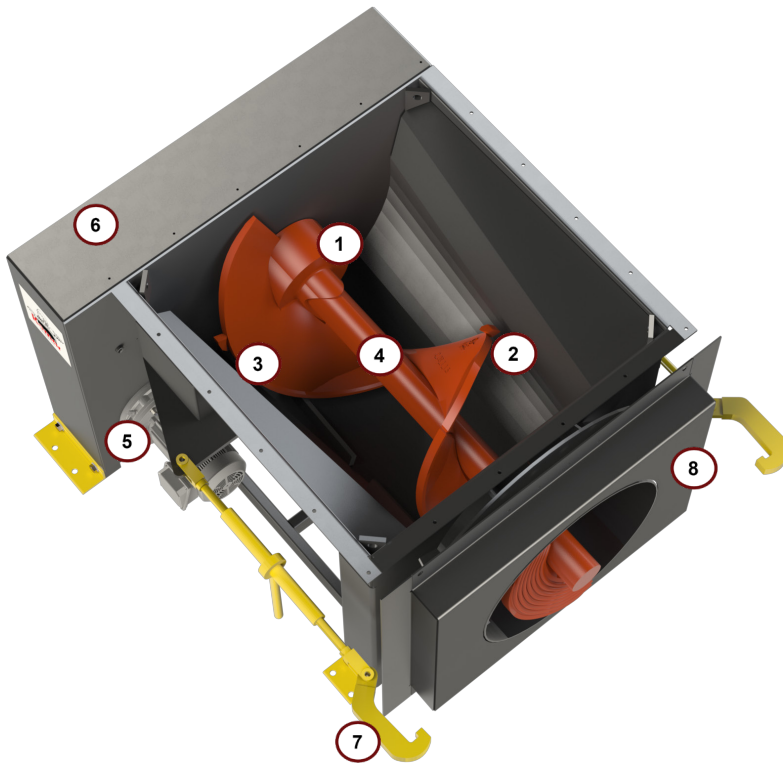

③ Cast Alloy Steel Flights ④ Tapered Solid Alloy Steel Shaft

Using the highest quality components to construct our auger screws extends service life. The mass and shape of the cast flights increases overall strength and durability, while providing more efficient material delivery to the receiving container. Our patented tapered shaft uniquely distributes force along the shaft, minimizing stress on the bearings and maximizing screw life.

⑤ Cycloidal Drive with 500% Shock Load

Don't judge a drive strictly by the motor's horsepower, especially when you plan to process heavy industrial materials. A high shock load rating is important in giving the compactor the ability to crush through large loads without damage to the drive.

⑥ Worry-Free Chain and Bearing Lubrication System

The engineered, automatically lubricated chain, coupled with the self-lubricating bearing system with automatic grease purge cuts down on routine maintenance.

⑦ Ratchet Binders ⑧ Container Adaptor

The auger compacts directly into a standard roll-off receiving container typically provided by your local hauler, and meets ANSI and OSHA specifications.

Groveport, OH

(614) 836-2366

www.komarindustries.com

info@komarindustries.com