



Komar Auger-Pak®

Quality Made
in the USA



Since 1977

Heavy-Duty Industrial General Waste Compactor

EM-20G



EM-20G with optional dock enclosure hopper

- Located outside your facility
- Shreds and compacts in one machine
- Significant volume reduction increases payload weights & lowers transportation costs
- No issues with “spring-back” or “drag-back”
- No material build-up to attract pests
- Connects to standard receiving container
- Clean quiet electric drive, no hydraulic leaks

Komar EM-20G Auger-Pak®

Komar's EM-20G Auger-Pak® is a heavy-duty industrial compactor, ideal for medium volume general waste applications. Maximizing density up to five times, and packing four to eight tons of material directly into a 40 cubic yard container, this unit easily keeps pace with competitive technologies while offering several operational advantages. The continuous forward processing motion prevents the spring-back and bridging issues common in ram style compactors. Material build-up is eliminated, preventing the attraction of rodents and pests. It has a clean electric drive system; and the small footprint frees up space for other business operations. Komar uses high quality, precision made parts to ensure significantly increased machine life with very low maintenance.



* Load weights vary depending on material and loading method.

Groveport, OH

(614) 836-2366

komarindustries.com

sales@komarindustries.com

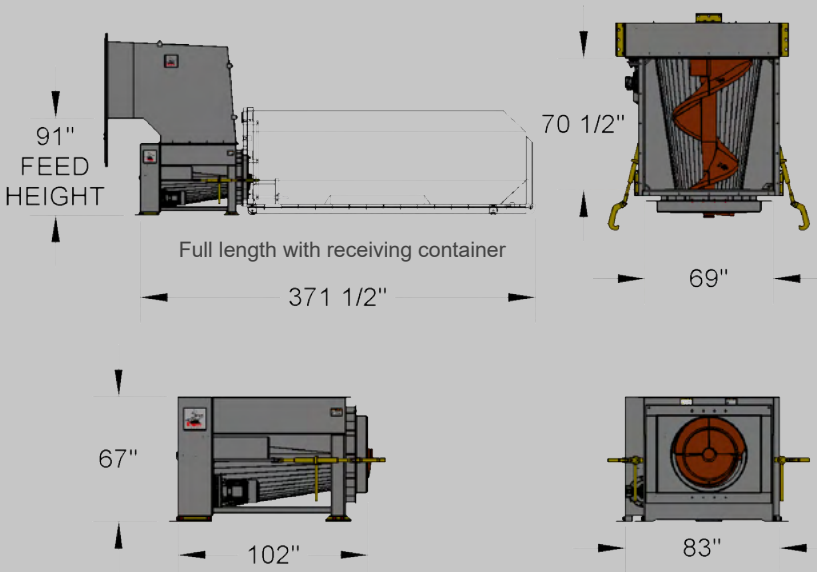

Processing Specifications	
Horsepower	20
Peak Tons per Hour	4.9
Feed Type	Hand, Forklift, Tipper, Conveyor
Receiving Container	Roll-Off up to 40 cu. yd.
Tons Per Container	4-8

Physical Specifications	
Footprint (L x W x H)	102" x 83" x 67"
Chamber Size (L x W)	70" x 69"
Full System Weight (lbs)	15,275
RPM / Torque (ft-lbs.)	5.97 / 17,602

Dimensions and process data for reference only

Dock Enclosure

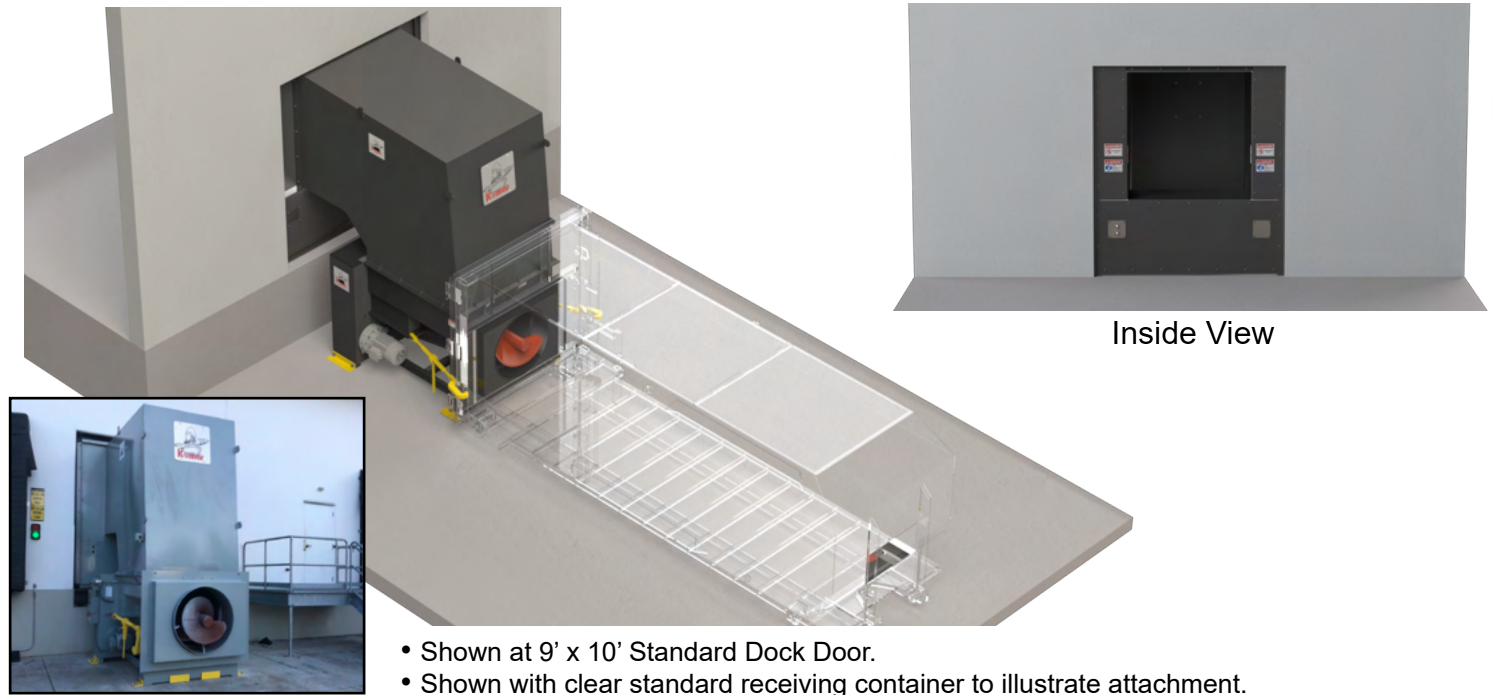

INSTALLATION TYPES

Yard

Installation Requirements	
Footprint w/ Concrete Pad	386" x 109"
Power Requirement	480 V, 3 PH, 60 Hz
Overcurrent Protection	50 amp MCP type breaker

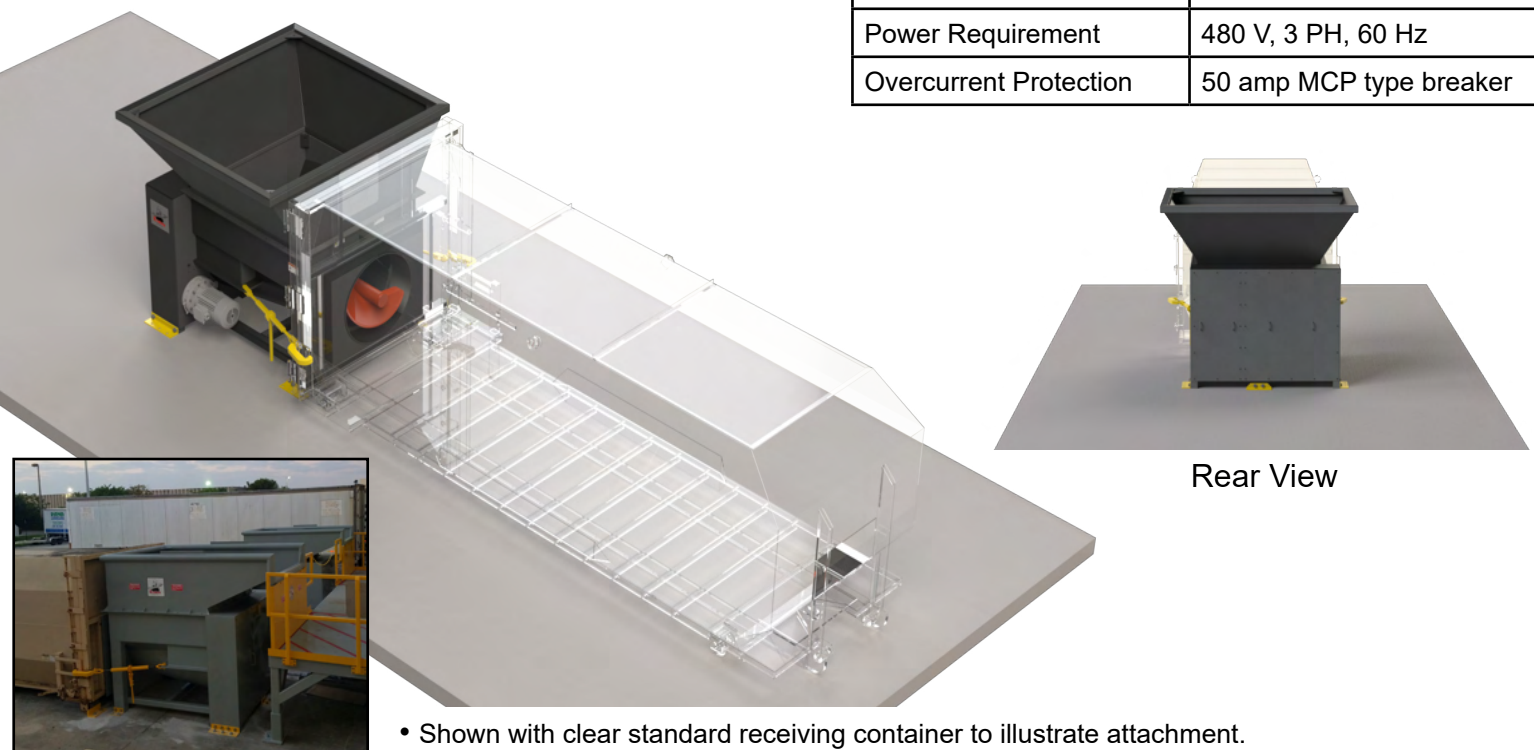

Dock Enclosure with Tipper

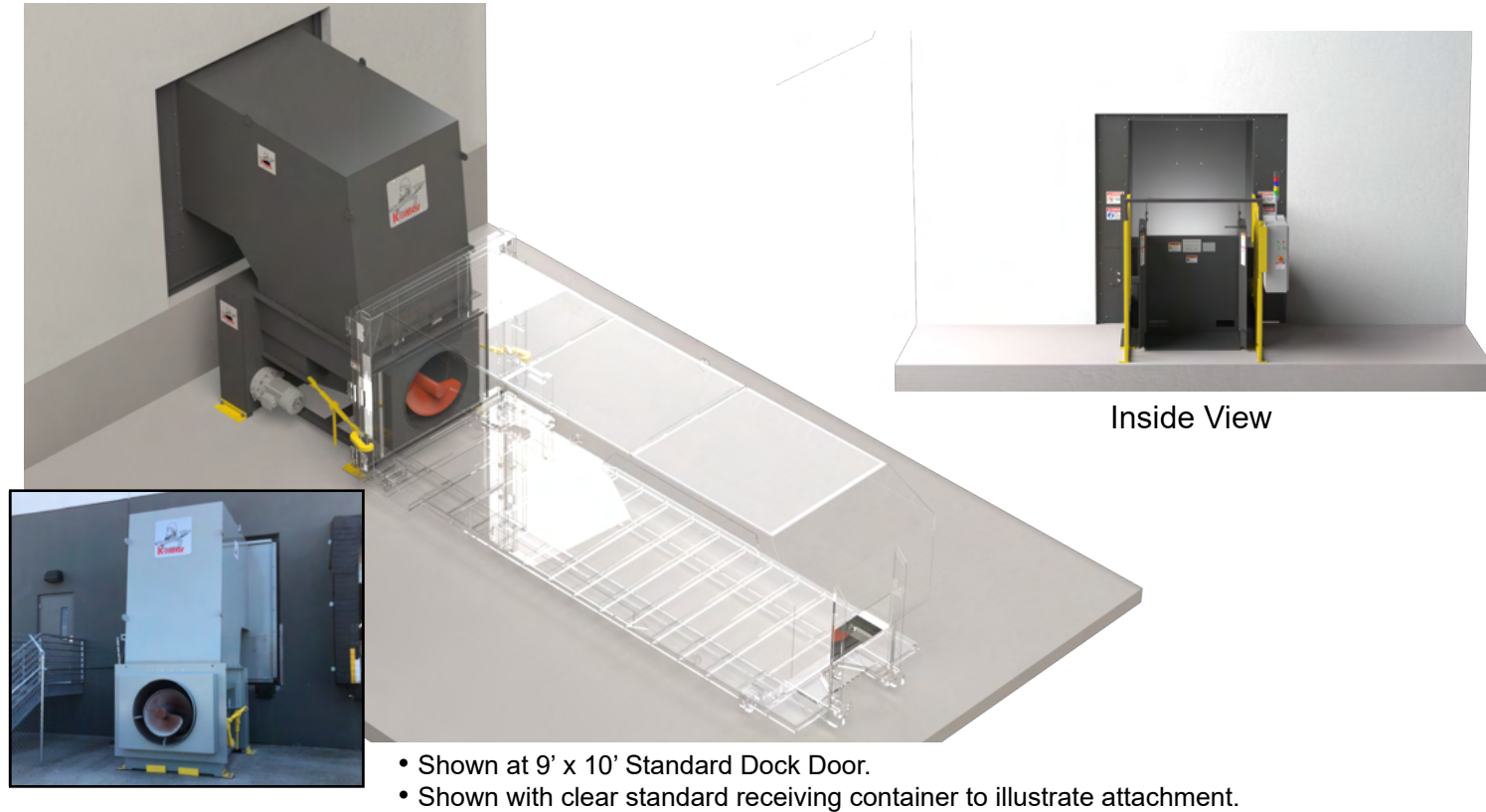



Komar Auger-Pak®

EM-G Technology Overview

① Patented Solid Lube Bearing Support System

Allows for the use of the biggest and most powerful auger screws in the industry, resulting in maximum compaction force.

② Worry-Free Chain and Bearing Lubrication System

The engineered, automatically lubricated chain, coupled with the self-lubricated bearing system cuts down on routine maintenance.

③ Cast Steel Push Flight ④ Tapered Solid Alloy Steel Shaft

Using the highest quality components to construct our auger screws extends service life. Other manufacturers bolt or weld solid steel end pieces onto a hollow pipe to form their auger shaft. This method is known as multi-piece construction and causes weak points where the pieces connect. Komar utilizes one continuous piece of solid steel. This single-piece solid steel shaft construction and our cast steel push flight increase the overall screw strength and durability.

⑤ Cycloidal Drive with 500% Shock Load

Don't judge a drive strictly by the motor's horsepower, especially when you plan to process heavy industrial materials. A high shock load rating is important in giving the compactor the ability to crush through large loads.

⑥ Ratchet Binders ⑦ Container Adaptor

The auger compacts directly into a standard roll-off receiving container typically provided by your local hauler, and meets ANSI and OSHA specifications.

